



### FEATURES

Lithium Iron Phosphate (LiFePO4): the Safest Lithium Technology.  
 Integrated Battery Management System(BMS).  
 Bluetooth/RS485/RS232/SMBus/CANBus (Optional).  
 SOC LED/LCD Indicator(Optional).

### PERFORMANCE

Long Cycle Life>6000cycles @80% DOD.  
 High Density, High Discharge Current, High Temperature Range.  
 Low Weight, Free Maintenance.  
 Fast Charging.  
 Environment Friendly.

### CHARACTERISTICS

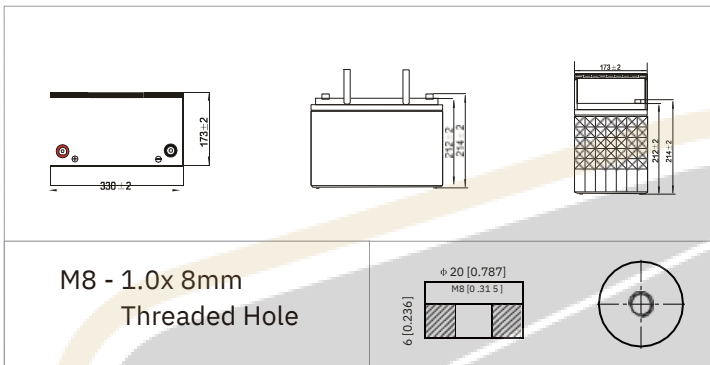

Item	Specifications
Nominal Voltage	12.8V
Rated Capacity	100Ah
Energy	1280Wh
Resistance	≤30mΩ
Efficiency	99%
Cycle Life	>6000cycles @ 80% DOD
Self Discharge	2% per Month
Max. Modules in Series/Parallel	4S/20P

Dimension(L x W x H)	330 x 173 x 212 mm 13 x 6.8 x 8.3"
Weight	11kg(24.2lbs)
Terminal Type	M8
Battery Housing	ABS, UL-94 V-0
Housing Protection	IP56
Cell Type-Chemistry	LiFePO4 Battery Cell
SoC Display	LED/LCD Indicator

Charge Method	Charge Voltage	CC-CV
Recommended Float Voltage		14.4~14.8V
Recommended Charge Current		13.8V
Maximum Charge Current		50A
BMS Charge Cut-off Voltage		100A
		15.6V

Discharge Temperature	-20 to 60° C (-4 to 140° F)
Charge Temperature	0 to 45° C (32 to 113° F) 0
Storage Temperature	to 60° C (32 to 140° F)*
BMS High Temperature Cut-off	80° C(176° F)

Continuous Discharge Current	100A
Pulse Discharge Current	300A(<3 seconds)
Recommended Volt. Disconnect	10V
BMS Discharge Cut-off Voltage	8V
Reconnect Voltage	9.2V
Short Circuit Protection	200~600 us

## CHARACTERISTICS

- + Data Center UPS
- + Telecom Backup Power
- + Military Power Supply
- + Solar Energy Storage System
- + Solar Street LED Lightings
- + Autonomously Guided Vehicles (AGVs)
- + Industrial Robotics & Handling Equipment
- + Aerial Work Platform
- + Floor Cleaning Machines
- + Power Tools, Lawn Mower
- + Electric Bike & Motorcycles
- + Electric Mobilities(E-scooters,Wheelchair)
- + Golf Trolley & Golf Carts
- + Medical Devices
- + Electric Ships
- + Passenger Vehicles

DISCHARGE CAPACITY at VARIOUS TEMPERATURES  
DISCHARGE @0.5C, 25 C°

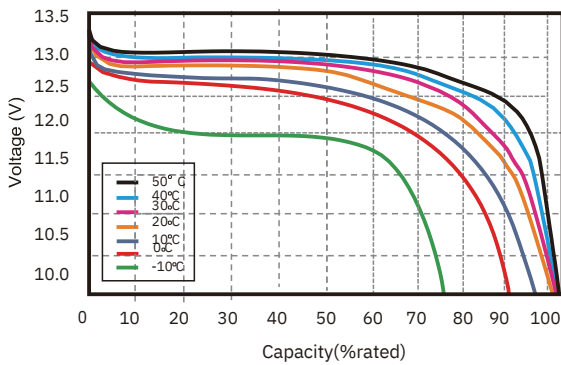

CHARGING CHARACTERISTICS @0.5C, 25 C

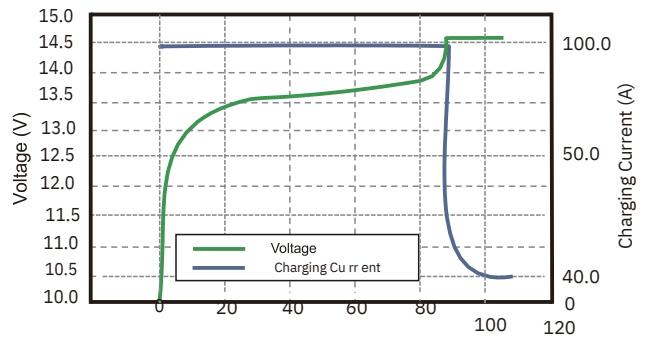

CYCLE LIFE vs.DEPTH OF DISCHARGE(DOD)  
DISCHARGE@0.5C, 25 C°

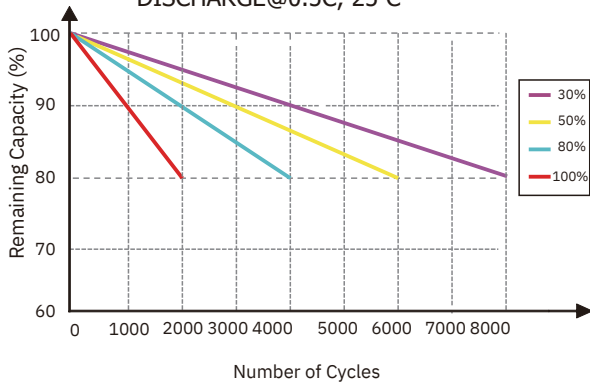

STATE OF CHARGE CURVE @0.5C, 25 C

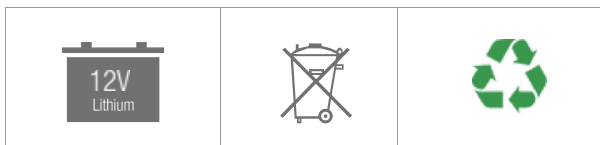
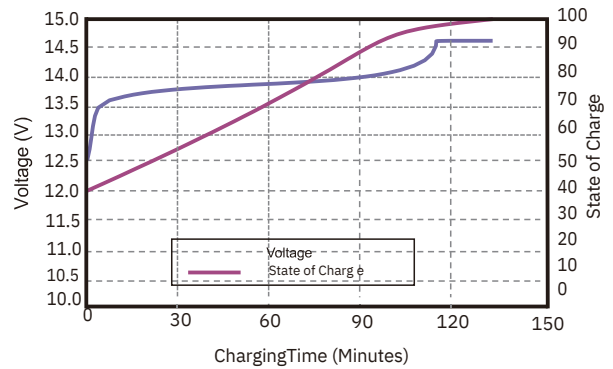

[www.exelonest.com](http://www.exelonest.com)



**NOTE:** Do Not Mix With Sealed Lead Acid Batteries When Recycling.

0 212 875 31 81

[www.teknovasyonarge.com](http://www.teknovasyonarge.com)