



LITHIUM BATTERY PACK

ESS-48V 200Ah



FEATURES

Lithium Iron Phosphate (LiFePO4): the Safest Lithium Technology.
 Integrated Battery Management System(BMS).
 Bluetooth/RS485/RS232/SMBus/CANBus (Optional).
 SOC LED/LCD Indicator(Optional).

PERFORMANCE

Long Cycle Life>6000cycles @80% DOD.
 High Density, High Discharge Current, High Temperature Range.
 Low Weight, Free Maintenance.
 Fast Charging.
 Environment Friendly.

CHARACTERISTICS

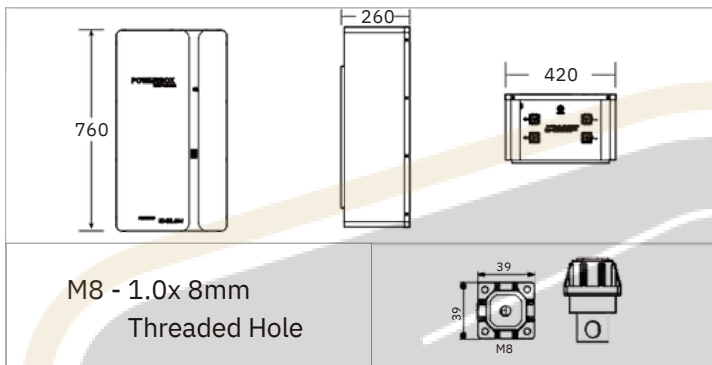

Item	Specifications
Nominal Voltage	48V
Rated Capacity	200Ah
Energy	9600Wh
Resistance	≤ 30mΩ
Efficiency	99%
Cycle Life	>6000cycles @ 80% DOD
Self Discharge	2% per Month

Dimension(L x W x H)	420 x 260 x 760 mm 16.53 x 10.23 x 29.92"
Weight	84kg(185.2lbs)
Terminal Type	M8
Battery Housing	Metal
Housing Protection	IP56
Cell Type-Chemistry	LiFePO4 Battery Cell
SoC Display	LED/LCD Indicator

Charge Method Charge Voltage	CC-CV
Recommended Float Voltage	54~55.5V
Recommended Charge Current	51.75V
Maximum Charge Current	50A
BMS Charge Cut-off Voltage	100A
	58.5V

Discharge Temperature	-20 to 60 °C (-4 to 140 °F)
Charge Temperature	0 to 45°C (32 to 113 °F)
Storage Temperature	0 to 60°C(32 to 140 °F)
BMS High Temperature Cut-off	80°C(176 °F)

Continuous Discharge Current	200A
Pulse Discharge Current	300A(<3 seconds)
Recommended Volt. Disconnect	37.5V
BMS Discharge Cut-off Voltage	30V
Reconnect Voltage	34.5V
Short Circuit Protection	200~600 us

0 212 875 31 81

www.teknovasyoncharge.com

CHARACTERISTICS

- + Military Power Supply
- + Solar Energy Storage System
- + Solar Street LED Lightings
- + Industrial Robotics & Handling Equipment
- + Aerial Work Platform

DISCHARGE CAPACITY at VARIOUS TEMPERATURES
DISCHARGE @0.5C, 25 °C

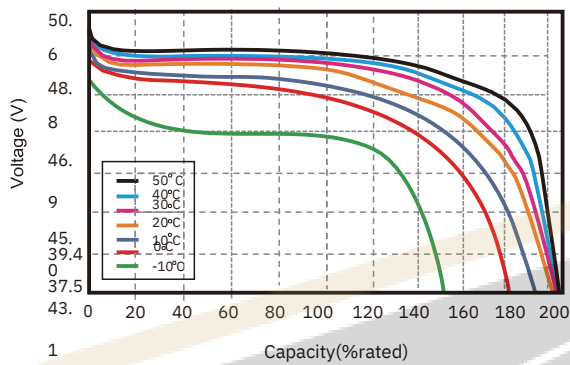

CHARGING CHARACTERISTICS @0.5C, 25 °C

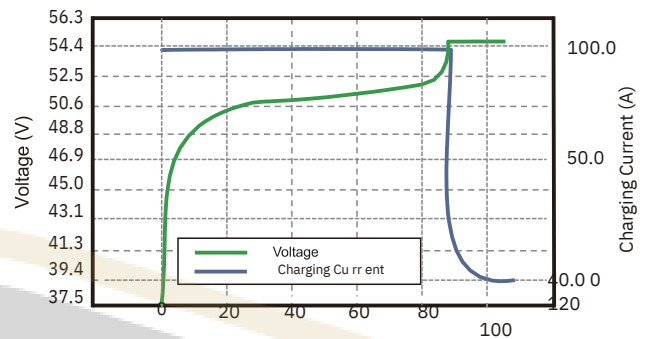

CYCLE LIFE vs. DEPTH OF DISCHARGE (DOD)
DISCHARGE @0.5C, 25 °C

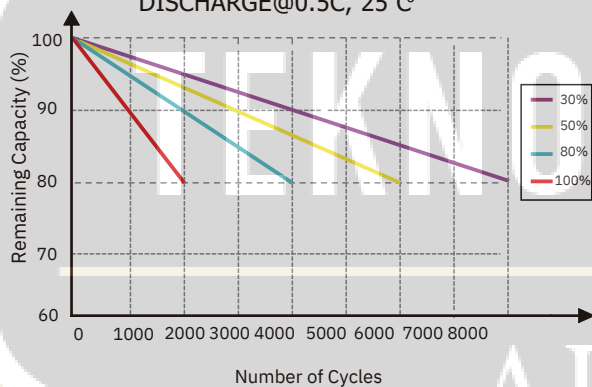

STATE OF CHARGE CURVE @0.5C, 25 °C

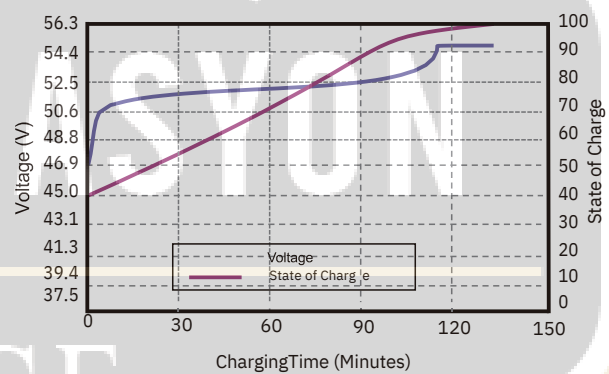

www.exelonest.com

NOTE: Do Not Mix With Sealed Lead Acid Batteries When Recycling.



0 212 875 31 81

www.teknovasyonarge.com